

## UTS LADDER 1450/850

### Instruction Manual

#### Mobile Access Tower

#### 3T - Through the trap method



### Instruction Manual

This Assembly Guide is intended to provide you with step-by-step instructions on how to erect your Mobile Access Tower (MAT) with ease and safety, using the 3T (through the trap) method.

You should read and understand all notes and diagrams, including the parts list for each height, before commencing assembly. Personnel should be qualified or competent to erect this tower. Please consult the PASMA's code of practice for full information on the use of Mobile Access Towers.

Remember to do a risk assessment of the area where the tower is to be used before commencing erection.

This instruction manual shall be available on the location of use of the mobile access and working tower.

This mobile access and working tower shall only be used according to this manual without any modification.

Mobile access and working towers must only be used in accordance with national regulations.

UTS SALES & REPAIRS LTD

Manufactured to: BSEN1004-1:2020 CLASS 3 8/12 XXXD H2

Instruction Manual EN 1004-2 en



KM 617169

# HEALTH AND SAFETY WARNINGS

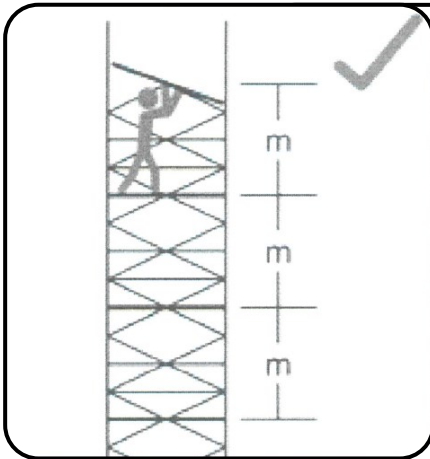

Maximum height between platforms of 2.2m

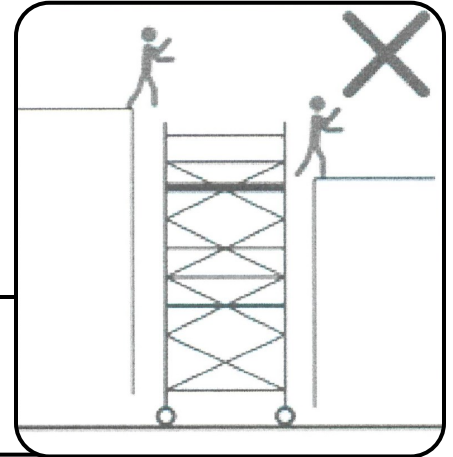

Do not use the tower as a form of access or exit

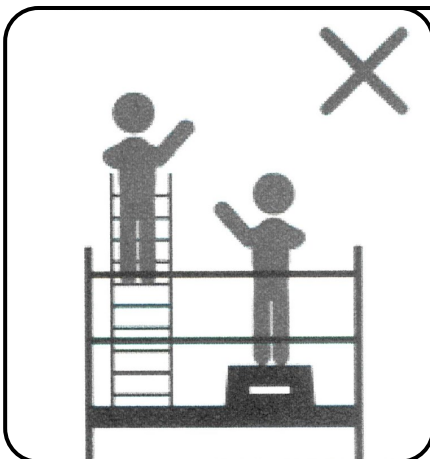

Do not use ladders, boxes or and other objects to gain additional height.

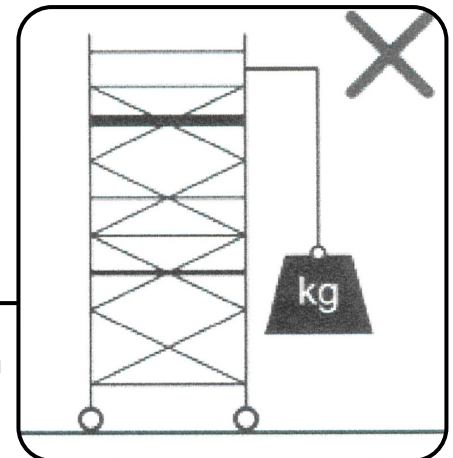

Do not lift heavy objects from the tower

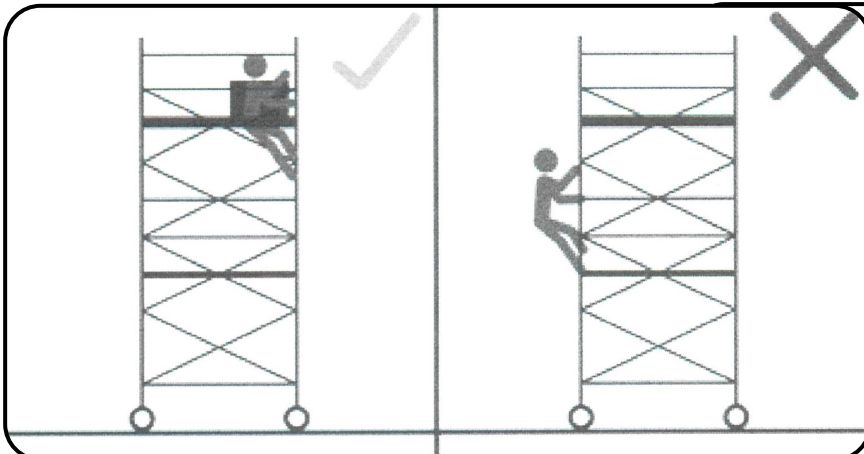

Do not climb outside of the tower, only climb up inside the tower.

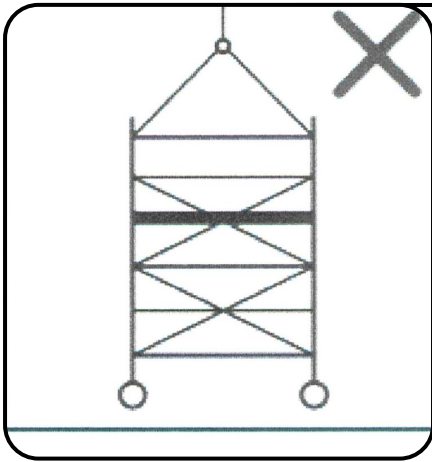

Do not suspend or lift the tower

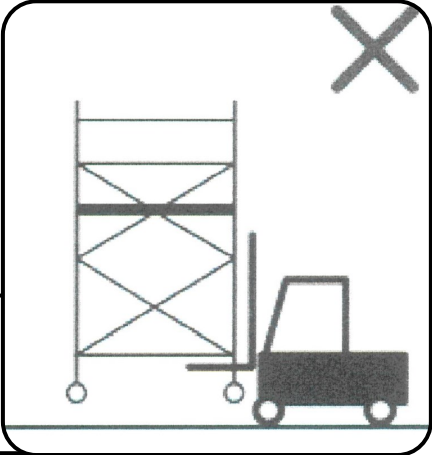

Do not lift the tower with mechanical equipment

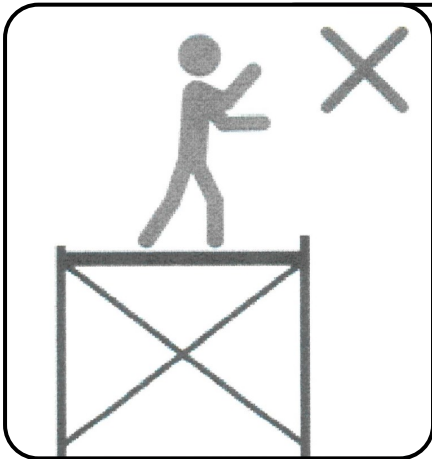

Do not stand up on an unguarded platform

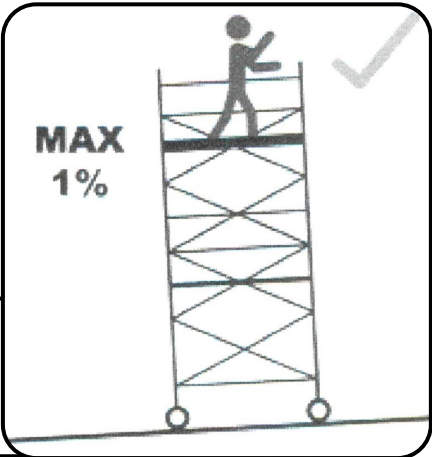

Maximum inclination for working = 1%

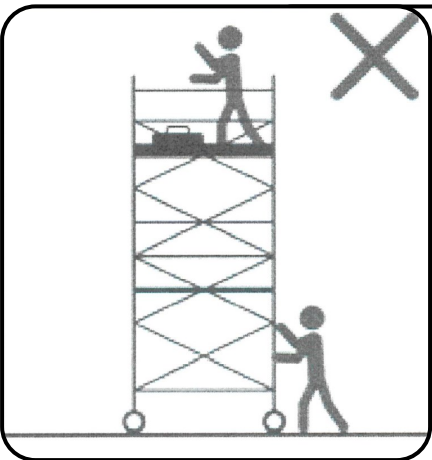

Do not move the tower with material or people on it

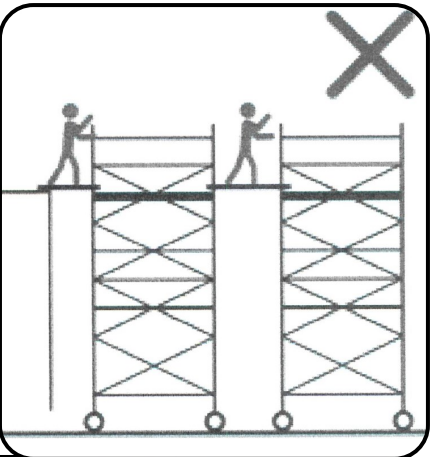

Do not bridge between towers or other structures

# UTS LADDER 1450/850

## Instruction Manual

### Mobile Access Tower

<b>Contents</b>	<b>Page</b>
Description	5
Safety Notes & Fittings	5
Inspection Care and Maintenance	7
Components and Weights	10
Assembly	11
Dismantling	18
Configurations and Weights	19
Risk Assessment Form	21

UTS SALES & REPAIR  
UNIT 1A CANTERBURY INDUSTRIAL PARK,  
ISLAND ROAD,  
HERSDEN,  
CANTERBURY,  
KENT,  
CT3 4HQ  
TEL:01227860085  
[WWW.TOWERSANDPODIUMS.CO.UK](http://WWW.TOWERSANDPODIUMS.CO.UK)

# Description, Safety Notes & Fittings

## Description

The UTS 1450/850 tower is manufactured to BSEN1004-1:2020 CLASS 3 8/12 XXXD H2 and KITEMARKED. The KITE MARK is the universal symbol that reassures the user that the product is certified to BSI stated standards.

- Instructions for erection and use to be followed carefully.
- A risk assessment should always be carried out before erecting your MAT (Mobile Access Tower).
- You will find a standard risk assessment form at the back of this instruction manual.
- The UTS 1450/850 has a maximum working platform height of 8.2 meters outdoors and 12.2 meters indoors.
- The maximum permissible load on the UTS 1450/850 tower is 950kgs and evenly distributed on each platform is 275kgs. This must not be exceeded over the working height platforms, not including rest platforms.
- Maximum of 1 working platform per tower.
- Maximum of 2 people per working platform.
- Damaged or incorrect components shall not be used.

## Safety Notes

### ERECTION & DISMANTLING - THE 3T(through the trap) METHOD

Towers should be erected following a safe method of work, there are two approved methods recommended by 'Prefabricated Access Suppliers & Manufacturers Association' (PASMA) in co-operation with the Health and Safety Executive (HSE) & the "working at height regulations 2005"

The method used for erecting and dismantling the UTS 1450/850 tower is the 3T METHOD (through the trap).

This method ensures the operators erecting the tower position themselves in the trapdoor of the platform to add or remove horizontal guardrail braces for the level above the platform.

### **NEVER STAND ON AN UNGUARDED PLATFORM.**

Before assembly or erection of this Mobile Access Tower (MAT) please ensure that:

- A risk assessment has been done and all safety equipment is on site.
- The ground conditions will take the working loads of MAT as specified.
- Always check that the MAT is vertical, (Level, slope, uneven ground etc.) if levelling is required make sure you adjust legs, in line with instructions (use spirit level).
- Beware of (overhead) obstructions – live wires, electrical apparatus or moving parts of machinery or other.
- Wind conditions are within limits as specified. (Refer to page 6)
- Do not use boxes, ladders, or other devices on the platform to gain additional height.
- If in doubt DO NOT ERECT.
- Check that all components are on site and that they are in good working order before use (refer to the components and quantities shown at each stage). Auxiliary equipment and safety equipment. (ropes, etc)
- All platforms MUST have horizontal guardrails fitted.
- The tower should always be accessed from the inside using the ladder frames provided.
- Never climb up the outside.
- Do not use the guardrail braces as a rung or step.
- It is recommended that 2 persons erect this tower.
- The assembled tower should not be used as a means to enter or exit other structures, e.g. as a stair tower.
- Beware of horizontal forces (e.g., when using power tools on an adjacent structure), which could generate instability or overturning of the tower.
- Maximum distance between platforms is 2.25m, maximum distance to the first platform is 3.4m.
- Maximum horizontal force 20kgs.
- Mobile access and working towers are not designed to be sheeted
- The tower height used should be appropriate for the working height, e.g. within 2 meters above the platform

- User training courses cannot be a substitute for instruction manuals but only complement them.
- Only the original UTS components specified in the manual shall be used.
- Mobile access and working towers designed in accordance with BS EN 1004-1:2020 are not anchor points for personal fall arrest equipment.
- Working is only permitted on a platform with a complete side protection including guardrails and toe boards.
- Mobile access and working towers are not designed to be used as edge protection.

## STABILISERS & BALLAST

Stabilisers or outriggers and ballast shall always be fitted when specified. When using the MAT externally stabilisers must be fitted. Should ballast be required, a platform should be positioned on the lowest rung and the weights should be firmly attached to it and evenly distributed. For advice on ballast contact your supplier.

## LIFTING OF EQUIPMENT

Tools and other equipment should be hauled up by a person on the platform using rope or similar, through the trapdoor of the platform or within the tower footprint.

Please see footprint guide on page 16.

Safe working loads of platform and tower not to be exceeded.

## MOVING THE TOWER AND LEAVING IT UNATTENDED

- Adjust the stabilisers to provide ground clearance.
- Unlock the castor wheels.
- Move with manual force only, and only from the base.
- Beware of (overhead) obstructions – live wires, hanging apparatus or other objects.
- Do not move with people or material on the tower.
- Do not move the assembled MAT if wind speeds exceed a moderate breeze. Relock the castors and readjust the stabilisers once in the new position.
- When moving the tower over uneven or sloping ground remove all tools.
- Do not move the assembled tower if over 4 meters high.
- Recheck that the MAT is vertical or needs readjustment of legs before ascending. (Using spirit level)
- Mobile access and working towers shall only be moved on a flat and solid ground without obstacles and not on a slope of more than 10mm/1m

It is recommended that towers should be tied to a solid structure, when left unattended.

## TIES

When ties are required, they should be in accordance with table 17 of BS 5973:1990 and table 24 of BS 5975:1982. Always tie to a solid structure.

The tie frequency should be at 4 meter intervals or less vertically.

## FITTING TOE-BOARDS

**1 piece folding aluminium toe-board**, fold out over platform making sure location angle rests fits securely on side of platform.

**4 piece wooden planks and clips**. Fit toeboard clip to each corner of the platform(s). Then fit planks into slots between clips.

## LIFTING OF INDIVIDUAL TOWER COMPONENTS

Raising and lowering components, tools and/or materials by rope should be conducted within the tower base (i.e. within the area bounded by the stabilisers). Ensure that the safe working load of the supporting decks and the tower structure is not exceeded.

Check for environmental changes before every use. (ie: all weather conditions) Refer to next page for wind effects.

# CHECK LIST, INSPECTION CARE AND MAINTENANCE FOR MOBILE ACCESS TOWERS

- All components should be inspected before use to ensure that they are not damaged or broken, particularly the welds.
- ANY damage to ANY part particularly tubular members, castors, platform decking MUST be replaced.
- Adjustable leg threads should be cleaned and lightly oiled.
- All locking claws should be cleaned, and the locking mechanism checked for operation.
- When storing your MAT, please ensure that all components are neatly stored and not left lying around where they could be stood on or damaged.
- When transporting the MAT always tie the components down so that they do not move around and get damaged.
- Should the tower be left unattended it should be tied to a suitable structure and on reuse ALWAYS check that the tower is vertical and safe before ascending correct and complete structure.
- The MAT is not designed to be lifted or suspended as a complete structure.
- Always keep this instruction manual safe.
- Broken, damaged or incorrect components must never be used. The equipment shall be quarantined and assessed for replacement repair or destruction.

## WIND EFFECTS

- Beware of high, gusty, or moderate breeze conditions in exposed areas. It is recommended that in wind speeds over a Moderate Breeze (see Beaufort Scale below) that work on the tower is stopped and reassessed. If the wind becomes a Strong Breeze, (see Beaufort Scale below) the tower should be tied to a rigid structure. If the wind is likely to reach Gale Force (see Beaufort Scale below) or over, work should be stopped, and the tower should be dismantled.
- Beware of tunnelling effect caused by open ended buildings, uncladded buildings and building corners.

Wind	Beaufort Scale 10 Meters above ground	Force	Speed in m.p.h.	Speed in knots
Moderate Breeze	Raises dust and loose paper, small branches move.	4	13–18	11–16
Strong Breeze	Large branches in motion, telegraph wires whistle.	6	25–31	22–27
Gale Force	Walking is difficult, twigs break off trees.	8	39–46	34–40

### LOCKING CLIPS

Fit the locking clips as shown in the diagram opposite.

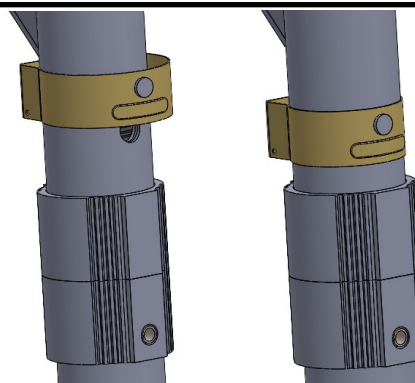

## LOCKING CASTORS

Castor wheels should be pointed outwards at approximately 45 degrees and locks engaged as shown opposite.

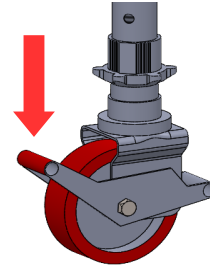

## FITTING STABILISERS

To attach stabilisers clamps, undo palm wheel all the way, fit one side of clamp to vertical frame, then rotate second side of clamp to fit vertical frame and tighten palm wheel.

Attach a stabilisers in configurations as shown on pg18 for maximum stability in different situations.

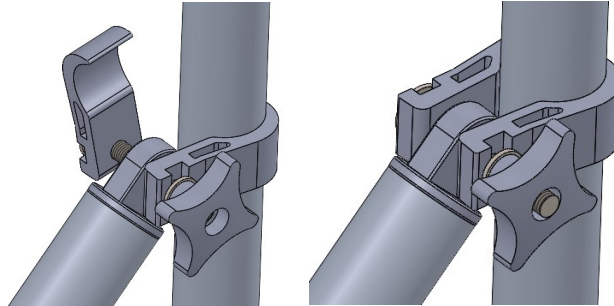

## CORRECT FITTING OF HORIZONTAL BRACING

THE CORRECT FITTING OF HORIZONTAL BRACING IS IMPORTANT.

The diagrams opposite illustrate the CORRECT brace positions.

REMEMBER: Always fit braces DOWNWARD or from the inside facing OUTWARD – BUT NEVER INWARD

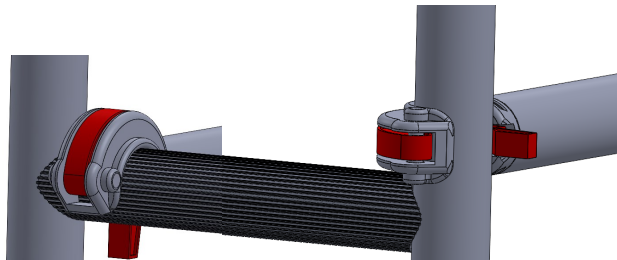

## BRACE CLAMP LOCKING

Ensure that the brace clamp is locked as shown.

Always make sure the brace is not clamped too close to the weld as indicated by the arrow on the drawing on the right.

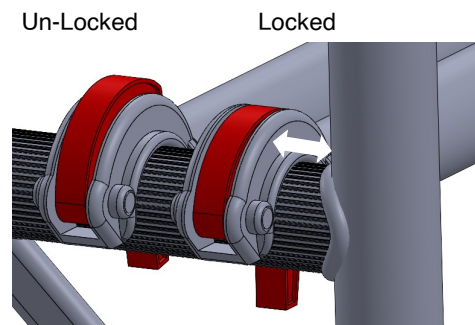

## FITTING ADJUSTABLE LEGS

Take the adjustable leg assembly complete with its castors, make sure that all the adjusting nuts are positioned down at the castor and slide them into the vertical tube, turn the base unit the right way up and with the aid of a spirit level placed on the platform, the adjusting nuts can be used to level the structure. (and not to gain additional height).



## PLATFORM WINDLOCK LOCKING

Make sure wind locks are pushed forward until they sit securely under the rung.

They should not be able to fall out and should require a reasonable pull to disengage them.

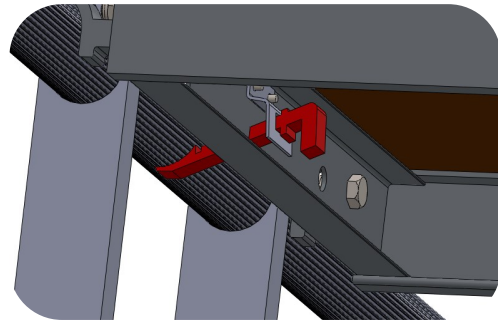

## FITTING TOE-BOARDS

### 1 piece folding aluminium toe board.

Unfold out over platform, hook bottom edges over sides of platform.

Ensure short ends of toe boards have hooked over both ends of the platform, hook bottom edge down between platform hook and frame.

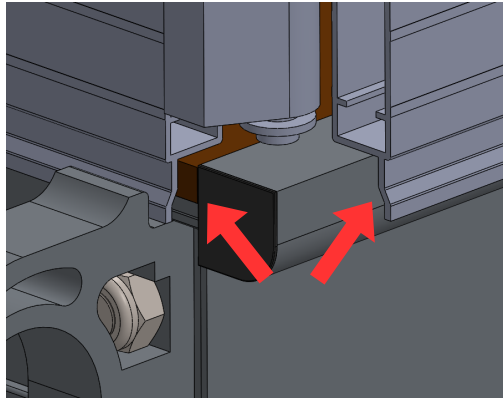
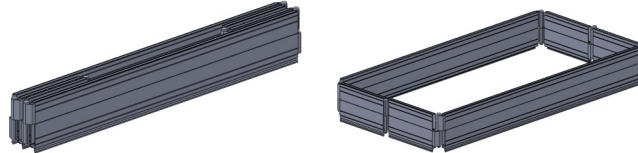

## FITTING TOE-BOARDS

### 4 piece wooden planks and clips.

Fit toeboard clip to each corner of the platform(s). Ensure clip straddles platform hooks and line up correctly with outside edge of platform.

Fit planks to inside slot at ends of platform and into the back slot for the edges.

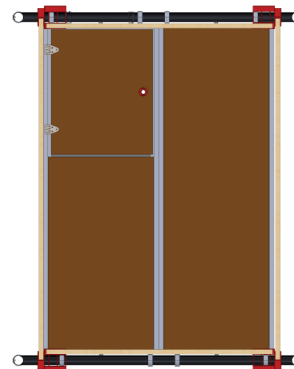
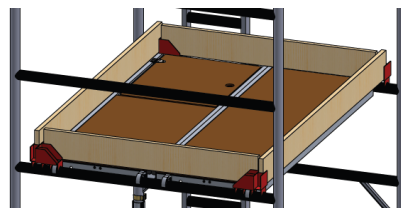
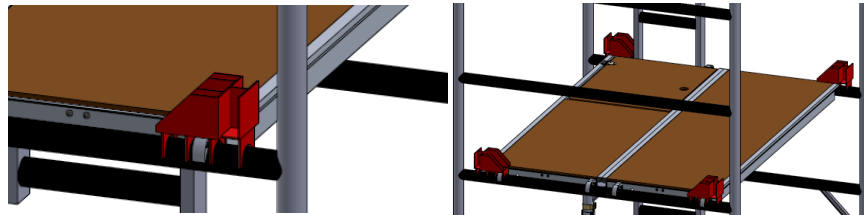

# Identifying Components and Their Weights

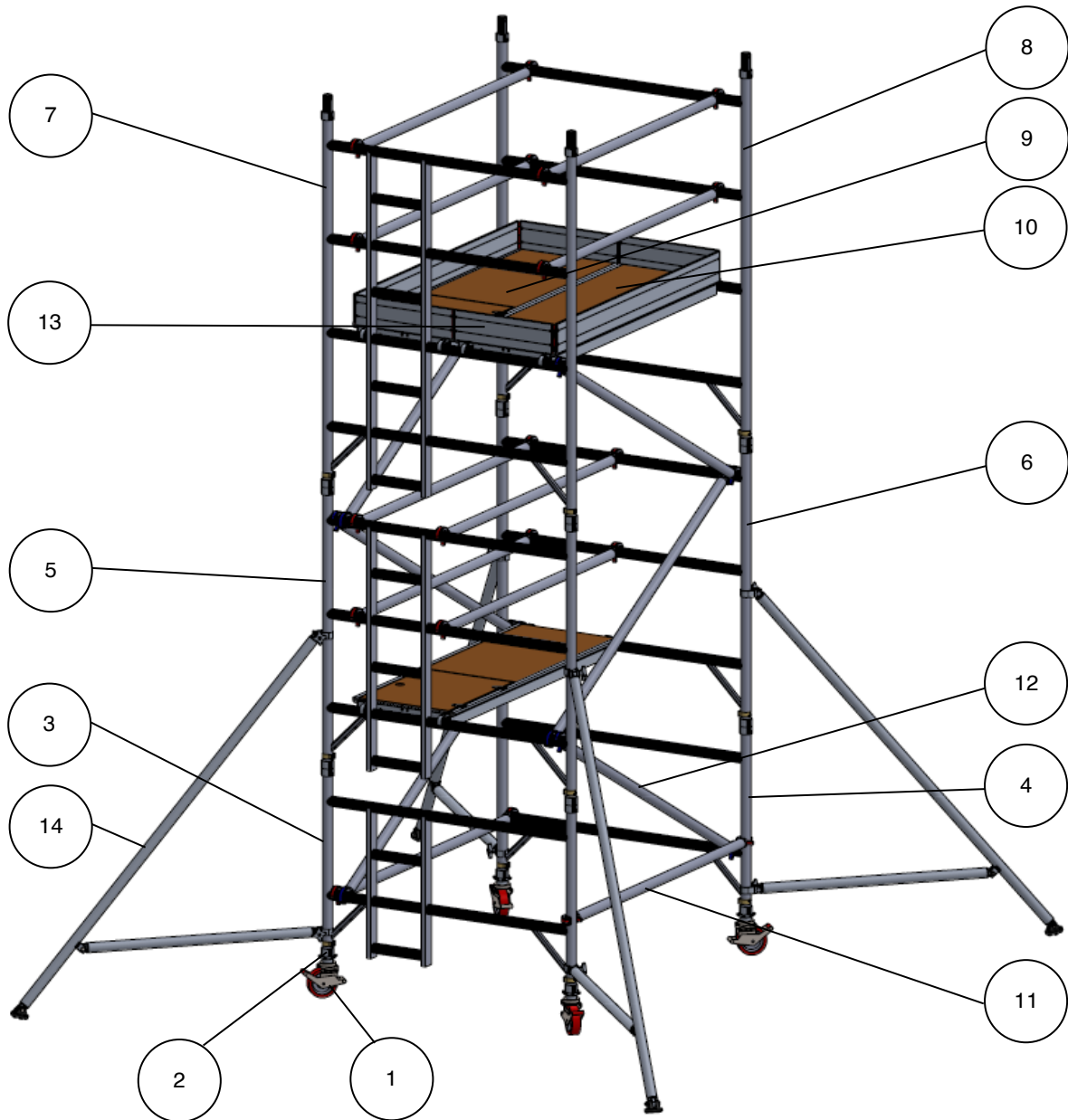

Note:  
When building structures over 4.2 metres remove platform and 4 horizontal braces from platform height at 2.2 metres and use to complete structure.

## Tower Components and Approx. Weights

Item	Description	Weight (Kg)	Item	Description	Weight (Kg)
1	150mm Locking Caster	3.4	9	1.8m Trapdoor Platform	12.7
2	Adjustable Leg 500mm	1.1	10	1.8m Fixed Platform	11.8
3	1m Ladder Frame	5.4	11	1.8m Horizontal Brace	2.1
4	1m Span Frame	4	12	2.1m Diagonal Brace	2.2
5	1.5m Ladder Frame	8	13	Complete Toe Board Set	8
6	1.5m Span Frame	5.6	14	S1 Stabiliser	4.1
7	2m Ladder Frame	10.4	15	S2 Stabiliser	5.9
8	2m Span Frame	7.1			

# Assembly Procedure

UTS recommends that a minimum of two people is required for the assembly of the UTS LADDER 850/1450 tower. Only climb the tower from the inside using the ladder section.

Platform Heights in Meters	1st Frame	2nd Frame
1.2, 3.2, 5.2, 7.2, 9.2, 11.2	4 Rung	4 Rung
1.7, 3.7, 5.7, 7.7, 9.7, 11.7	2 Rung	3 Rung
2.2, 4.2, 6.2, 8.2, 10.2, 12.2	2 Rung	4 Rung
2.7, 4.7, 6.7, 8.7, 10.7	3 Rung	4 Rung

1. Insert adjustable leg assembly (with castors or base plates) into the base of ladder frame, repeat this with the span frame. Lock all castor wheels

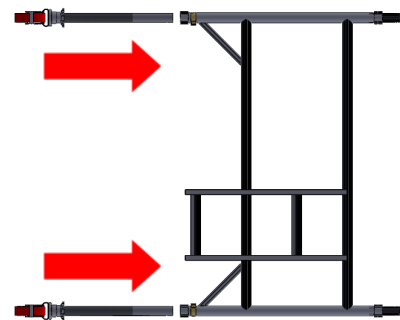

2. Attach one horizontal brace to the bottom rung of the span frame, claws facing downwards. This frame will now be self-supporting.

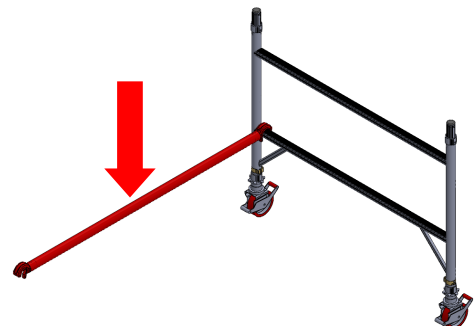

3. Position the ladder frame as shown. Connect the other end of the horizontal brace to the ladder frame. Now connect the frames using a second horizontal brace on the opposite side, attach from the inside of the frame just above the bottom rung, claws facing outwards, this will square the tower.

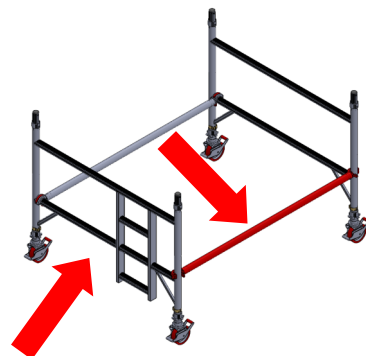

Check tower is vertical (Using spirit level)

## PLEASE TAKE NOTE

**Never place the platform on the guardrail frame**

**Always climb from the inside of the frame – never the outside. When working on the platform never overreach**

**The end frames should provide a firm hand hold.**

Insert 4 rung frames to correspond with the 2 rung frames (fig. 3) and lock the locking clips (refer to page 6).

4.

Attach diagonal braces on both sides from the 1st rung to the 3rd rung of the structure, in opposing directions.

Place a trap door platform on the 1st rung and a trap door platform on the 4th rung, both on the ladder side of the structure. Attach wind locks.

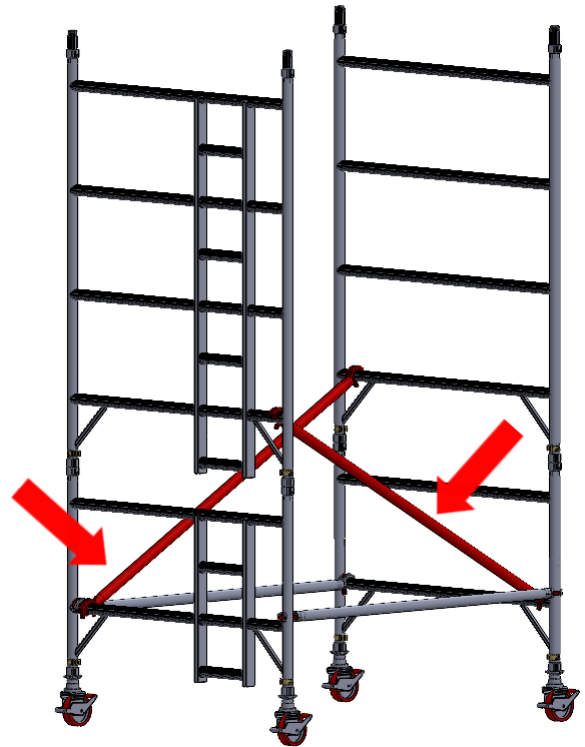
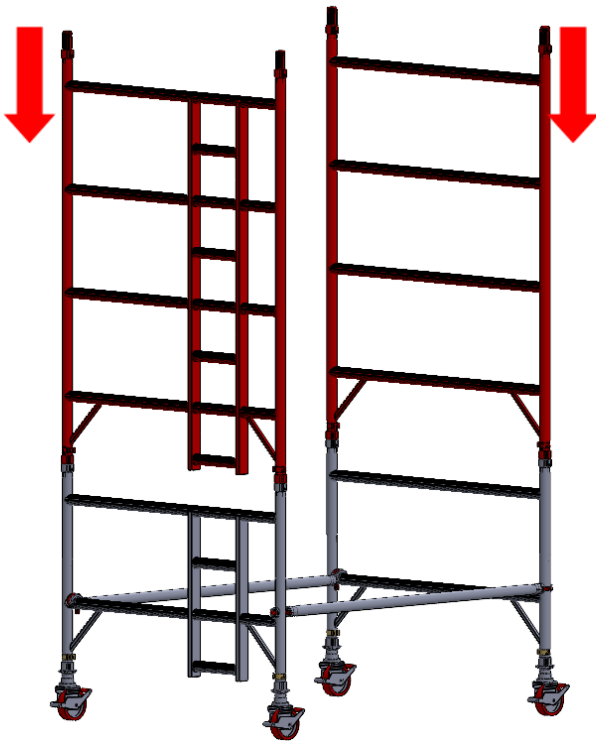

Attach stabilisers as required for working height (see table page 16).

5.

Climb the ladder and from a protected through the trapdoor position, attach horizontal guardrail braces to the 5th and then 6th rungs, on both sides of the platform.

Never climb onto a platform that is not fully guarded. Guardrails should be 1 and 2 rungs above platforms in all cases.

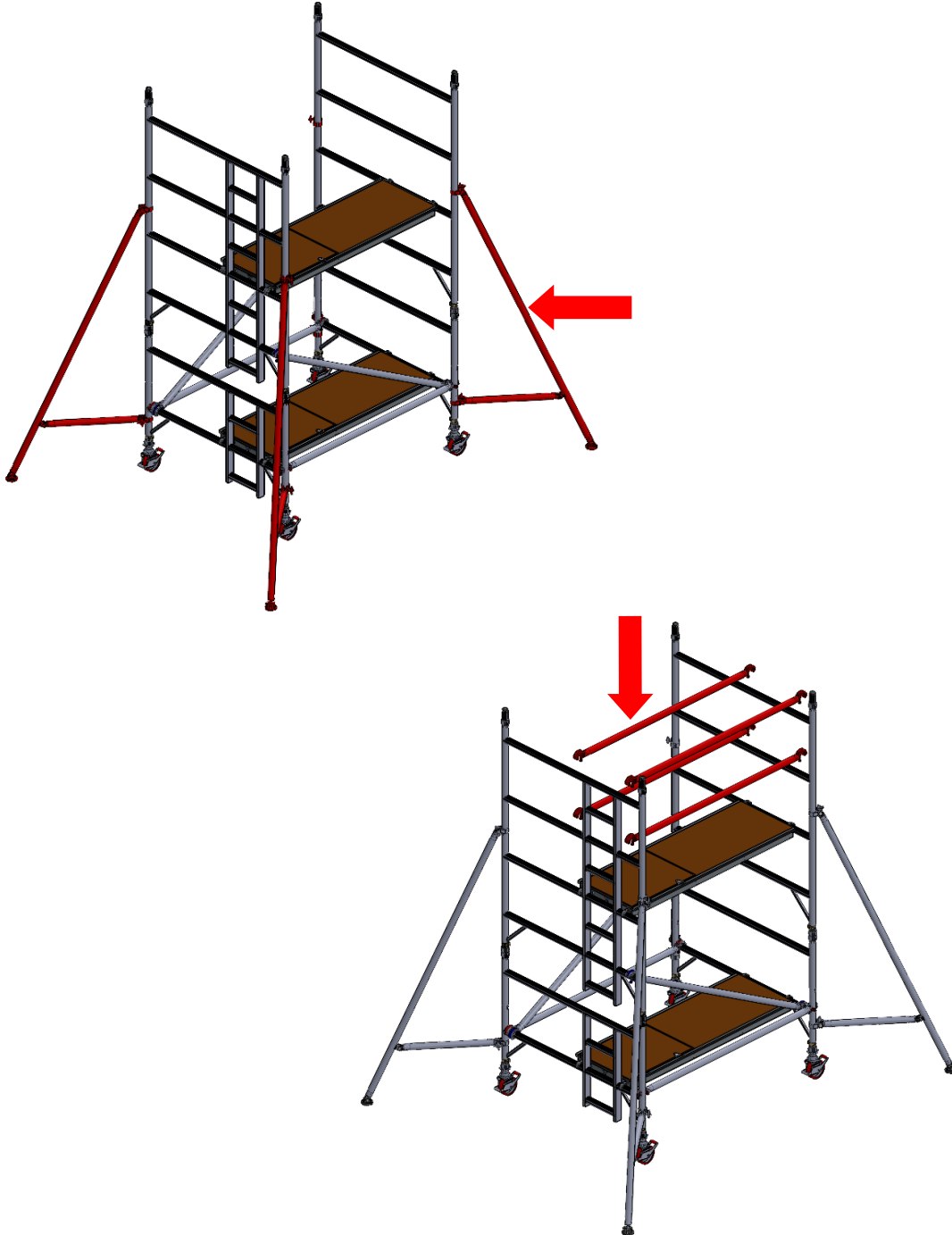

6. Attach 2nd pair of diagonal braces following on from the previous ones. Attach the next 4 rung frames and lock clips (as per fig. 6).

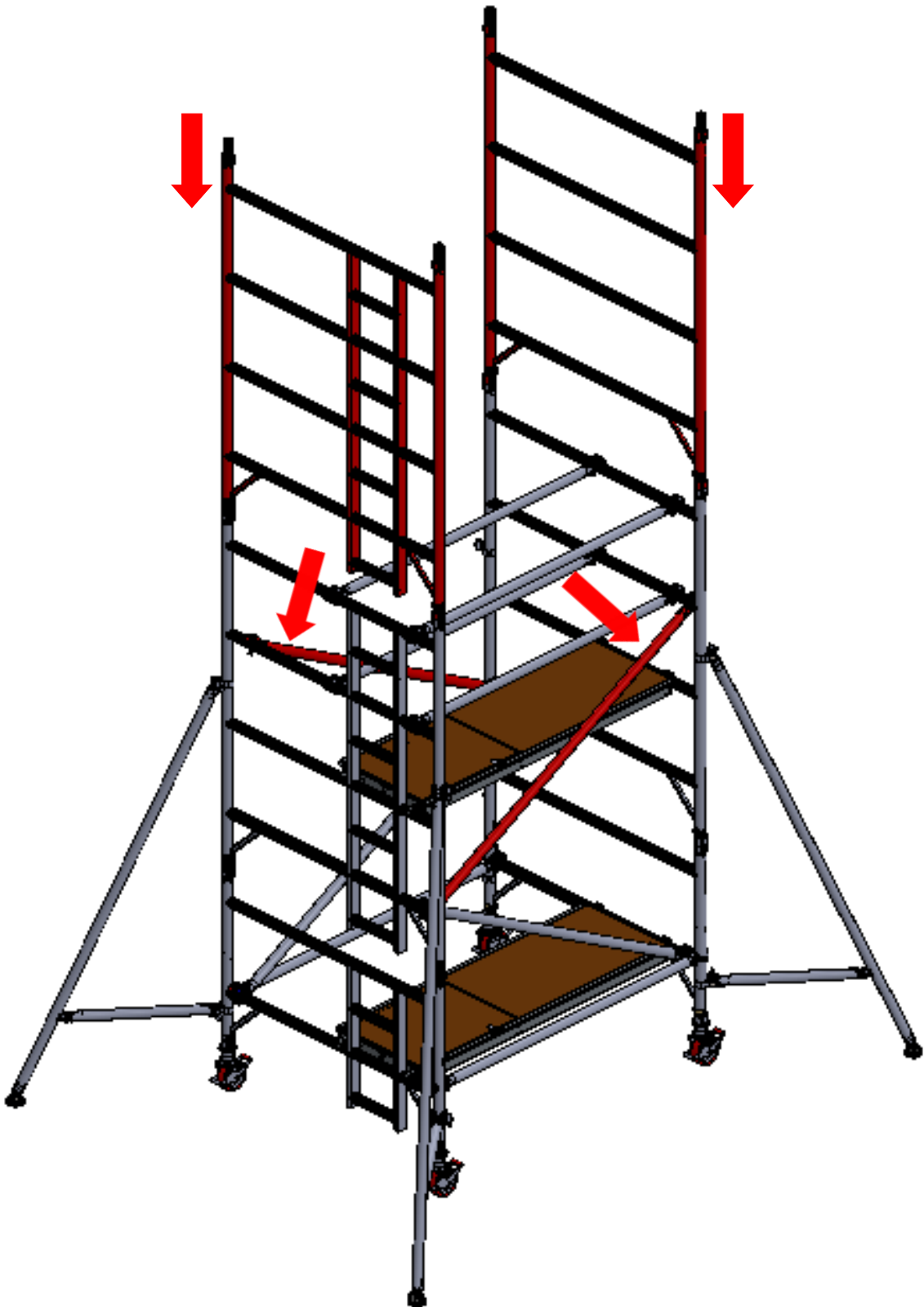

7.

If completing the tower at this height (4m), continue with step 8. When building beyond this level, repeat steps 4, 5 and 6 until desired level is achieved, then complete the tower with steps 8 and 9. Reuse the trap door platform from 1st rung on the final height.

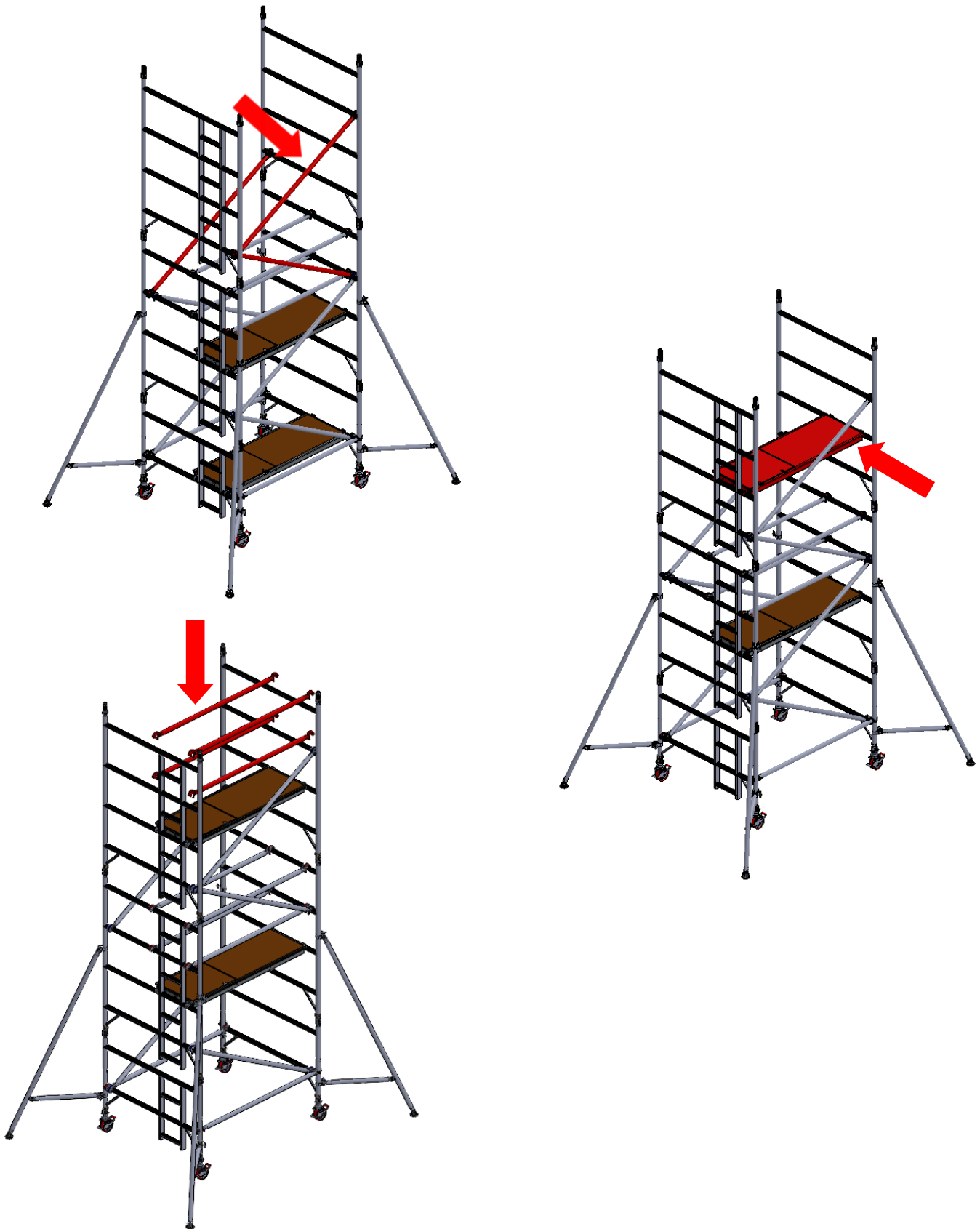

8.

Fit the final diagonal braces as shown. This stage will provide a platform height of 4m. Attach diagonal braces as per fig. 7. The 1st rung trap door platform should be moved up to the 8th rung, the fixed platform can now be fitted alongside it.

LOCK WIND LOCKS.

Climb up the ladder and from a protected 'through the trapdoor' position, fit horizontal guardrail braces to the 9th and then the 10th rungs on both sides of the tower. Complete the tower assembly by following step 9.



9. Fit toe boards to all working platforms either folding aluminium or toeboard clips and planks.  
(see instructions on page 9)



**Maximum distance between platforms should not exceed 2.25m.  
Maximum distance to first platform should not exceed 3.4m**

# Dismantling

The dismantling procedure should follow the assembly steps in reverse order, take particular attention about the removal of guardrails and platforms.

You should ensure that you are standing in a safe position and always protected by guardrails NEVER remove diagonal braces or stabilisers prematurely.

After removing the toe-boards the operator disengages the horizontal guardrail brace clamps furthest from the trap door, horizontal guardrail braces are then removed with the operator positioned through the trap door before descending to the lower level, from where the upper platform and extensions/guardrail frames can be removed.

## NOTES:

DO NOT OVER-REACH and NEVER DROP COMPONENTS when dismantling always lower them to the ground.

## STABILISERS

Attach one stabiliser to each corner of tower at approx. 45 degrees. The bottom clamp should be fitted as low as possible, refer to the diagram opposite. Ensure that all four rubber feet are in contact with the ground and that the clamps are secured. Position stabilisers as shown in the diagrams.

When using the S2 stabilisers, always extend the telescopic legs to their maximum position and lock into position with the interlock clip.

When moving the tower lock each telescopic leg just clear of the ground, unlock castors ensuring area is firm and clear of all obstructions both on the ground and above.

After moving check all castors are firmly on the ground and locked, and that the tower is vertical. Re-position stabilisers as above.

### STABILISERS—S1

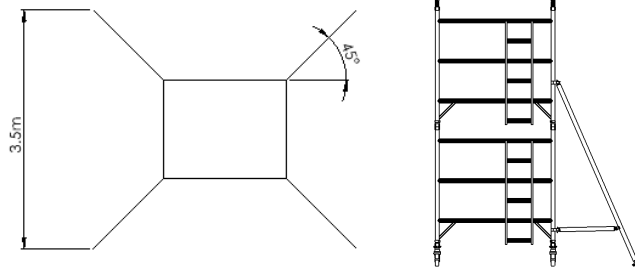

Static Stabiliser maximum platform height

Single Width 850  
Indoors 8.2m, Outdoors 8.2m

Double Width 1450  
Indoors 8.2m, Outdoors 8.2m

### STABILISERS—S2

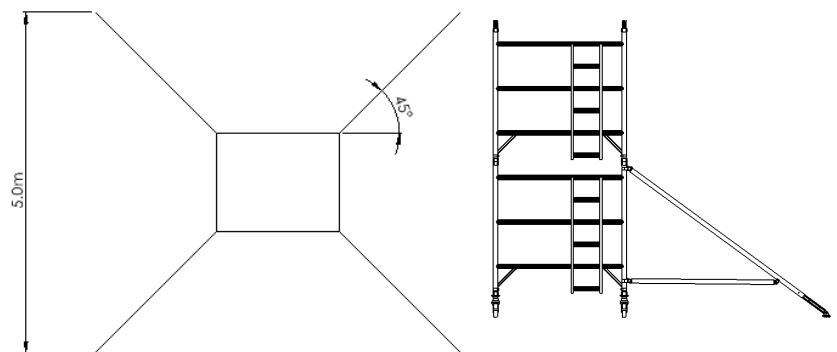

Telescopic Stabiliser maximum platform height

Single Width 850  
Indoors 8.7m-12.2m

Double Width 1450  
Indoors 8.7m-12.2m

# 850 Single Width

Configurations to BSEN 1004:-1:2020

Available in two lengths: 1.8m & 2.5m

## Working Height (M) Platform Height (M)

### INTERNAL AND EXTERNAL USE

### INTERNAL USE ONLY

Description	Approx Kg	INTERNAL AND EXTERNAL USE										INTERNAL USE ONLY												
		3.2	3.7	4.2	4.7	5.2	5.7	6.2	6.7	7.2	7.7	8.2	8.7	9.2	9.7	10.2	10.7	11.2	11.7	12.2	12.7	13.2	13.7	14.2
Castors	3.4	4	4	4	4	4	4	4	4	4	4	4	4	4	4	4	4	4	4	4	4	4	4	4
Adjustable Leg Unit	1.1	4	4	4	4	4	4	4	4	4	4	4	4	4	4	4	4	4	4	4	4	4	4	4
850 x 2 Rung Ladder Frame	4.9		1	1			1	1				1	1				1	1					1	1
850 x 2 Rung Span Frame	3.7		1	1			1	1				1	1				1	1					1	1
850 x 3 Rung Ladder Frame	7.7		1	1	1			1	1			1	1				1	1					1	1
850 x 3 Rung Span Frame	7.0		1	1	1			1	1			1	1				1	1					1	1
850 x 4 Rung Ladder Frame	9.5	1		1	1	2	1	2	2	3	2	3	4	3	4	3	4	3	4	3	4	3	4	6
850 x 4 Rung Span Frame	9.0	1		1	1	2	1	2	2	3	2	3	4	3	4	3	4	3	4	3	4	3	4	6
1.8m or 2.5m Fixed Platform	11.8 16.0																							
1.8m or 2.5m Trap Door Platform	12.7 16.3	1	1	1	2	2	2	2	2	3	3	3	4	4	4	4	4	4	4	4	4	4	6	6
1.8m or 2.5m Horizontal Brace	2.1 2.3	6	6	6	6	10	10	10	10	14	14	14	18	18	18	18	18	18	18	18	18	18	26	26
2.1m or 2.7m Diagonal Brace	2.2 2.4	2	3	3	4	5	6	7	8	9	10	11	12	13	14	15	15	15	15	15	15	21	22	23
S1 Stabiliser	4.1			4	4	4	4	4	4	4	4	4	4	4	4	4	4	4	4	4	4	4	4	4
S2 Stabiliser	5.9																							
Toe Board Clips	0.26	4	4	4	4	4	4	4	4	4	4	4	4	4	4	4	4	4	4	4	4	4	4	4
Single End Plank	0.9	2	2	2	2	2	2	2	2	2	2	2	2	2	2	2	2	2	2	2	2	2	2	2
1.8m or 2.5m side Plank	2.8 3.9	2	2	2	2	2	2	2	2	2	2	2	2	2	2	2	2	2	2	2	2	2	2	2
1.8m or 2.5m Aluminium Folding Toeboard	8.5 11	1	1	1	1	1	1	1	1	1	1	1	1	1	1	1	1	1	1	1	1	1	1	1
Approx. Tower Shelf weight (Kgs) Toeboard Clips and Planks 1.8m		74.6	81.6	101.8	21.9	137.2	144.2	150.2	158.5	185.6	192.6	198.6	206.9	234	241	247	247	247	247	247	247	338	345	351
Approx. Tower Shelf weight (Kgs) Aluminium Folding Toeboard 1.8m		74.7	81.7	101.9	122	137.3	144.3	150.3	158.6	185.7	192.7	198.7	207	234.1	241.1	247.1	247.1	247.1	247.1	247.1	247.1	338.1	345.1	351.1
Approx. Tower Shelf weight (Kgs) Toeboard Clips and Planks 2.5m		82	83.8	104	124.1	139.4	146.4	152.4	160.7	187.8	194.8	200.8	209.1	236.2	243.2	249.2	249.2	249.2	249.2	249.2	249.2	340.2	347.2	353.2
Approx. Tower Shelf weight (Kgs) Aluminium Folding Toeboard 2.5m		82.8	84.6	104.8	124.9	140.2	147.2	153.2	161.5	188.6	195.6	201.6	209.9	237	244	250	250	250	250	250	250	341	348	354





# Notes:

**UTS SALES & REPAIRS LTD**  
UNIT 1A CANTERBURY INDUSTRIAL PARK,  
ISLAND ROAD,  
HERSDEN,  
CANTERBURY,  
KENT,  
CT3 4HQ  
TEL: 01227 860085  
[WWW.TOWERSANDPODIUMS.CO.UK](http://WWW.TOWERSANDPODIUMS.CO.UK)



**KM 617169**

DOC NO: LT001, VERSION:1.2, DATE:01/03/24, APPROVED BY:A.GUNTRIPP, REVIEWED BY:M.GRANGER